

Sinusoidal output filters for VFD



Three phase sine wave voltage output filters especially designed for frequency converters.



LC filters of TORYTRANS remove pulses generated by the output voltage of the frequency converters PWM (pulse width modulation) at high frequencies and restore sinusoidal waveform at power converter's output.

Avoid the premature motor deterioration caused by high dV / dt , overvoltage and reflection wiring.

Increase significantly the motor's lifetime, reducing its overheating and eddy current losses.

Recommended for installations with cables over 50 up to 1000 meters between the frequency converter and motor.

Technical characteristics

Motor rating	0,37 ÷ 630 kW (0,5 ÷ 855 CV)
Nominal current	1 ÷ 1200 A
Converter output voltage	3 x 400 V ± 20 V
Converter output frequency	0 ÷ 70 Hz
Commutation frequency	5÷8 kHz up to LC050 3÷5 kHz LC060 to LC200 2÷3 kHz from LC250
Voltage distortion	≈ 8% THD-U
Drop voltage	<5% @ I_N 50 Hz
Insulation class	H (180°C)
Transitory overload	1,5 I_N 1 min x hour
Ambient temperature	50 °C
Protection degree	IP-20 (up to LC040) IP-00 (from LC050)
Safety class	Class I 
Thermal protection	150°C NC, 250V 6A
Standards	IEC/UNE-EN 60076-6  IEC/UNE-EN 61439-1

Electrical diagram

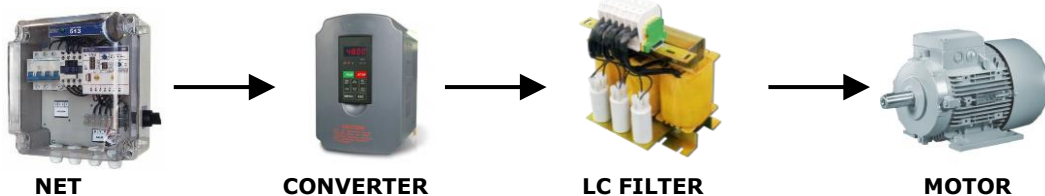
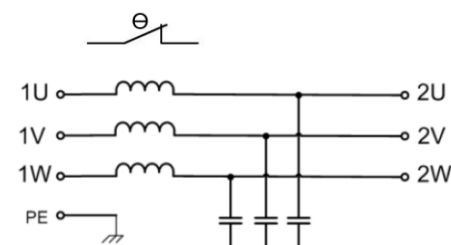

Output voltage-current comparative waveform of frequency converter

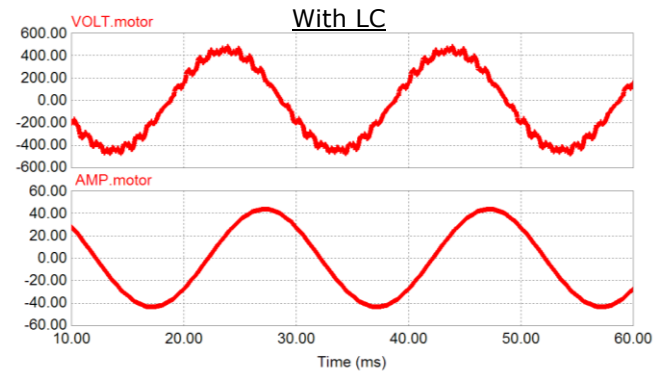
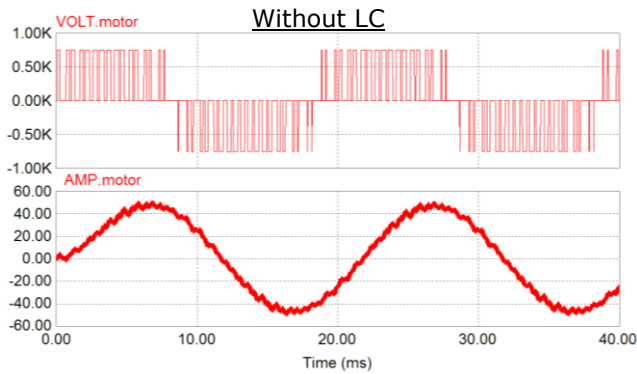

Select filter current according to motor rating.

Motor rating kW	CV	Rated current A	Reference	Dimensions mm						Weight kg	Losses W	Type
				A	B	C	D	E	Ø			
0,37	0,5	1	LC001	150	120	190	100	46	7	2,9	38	I
0,75	1	2	LC002	150	120	190	100	46	7	3,3	48	I
1,5	2	4	LC004	150	135	190	100	61	7	4,2	55	I
2,2	3	6	LC006	150	135	195	100	61	7	4,7	60	I
3	4	8	LC008	150	135	195	100	61	7	5	73	I
4	5,5	10	LC010	180	150	215	140	82	7	8,5	85	I
5,5	7,5	15	LC015	180	155	220	140	87	7	9,5	105	I
7,5	10	20	LC020	240	170	285	200	99	7	15	123	I
11	15	25	LC025	240	170	285	200	99	7	16	140	I
15	20	30	LC030	240	195	285	200	124	7	21	152	I
18,5	25	40	LC040	240	195	285	200	124	7	22	161	I
22	30	50	LC050	300	192	355	200	105	11	29	270	II
30	40	60	LC060	300	212	355	200	125	11	36	310	II
37	50	80	LC080	300	212	405	200	125	11	43	400	II
45	60	100	LC100	300	242	375	200	130	11	50	430	III
55	75	125	LC125	300	272	379	200	160	11	68	500	III
75	100	150	LC150	300	292	379	200	175	11	77	565	III
90	125	200	LC200	360	318	473	240	174	11	90	730	III
110	150	250	LC250	420	318	543	280	169	11	110	960	III
150	200	300	LC300	420	355	550	280	194	11	135	1050	III
185	250	400	LC400	420	380	550	280	219	11	160	1220	III
220	300	500	LC500	480	360	610	320	210	11	195	1480	III
300	410	600	LC600	480	365	610	320	215	11	210	1500	III
400	545	800	LC800	480	385	610	320	235	11	250	1600	III
530	720	1000	LC1000	540	390	680	360	242	13	285	2000	III
630	855	1200	LC1200	540	430	680	360	282	13	360	2225	III

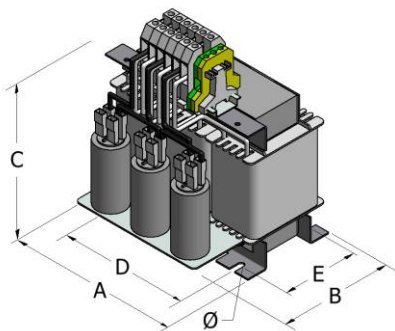

Type I

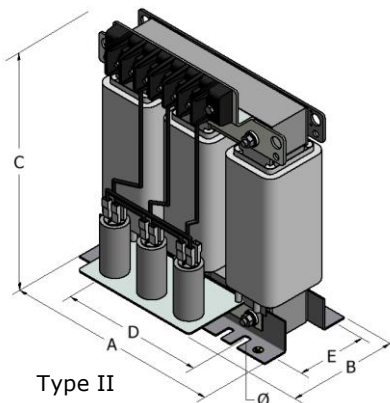

Type II

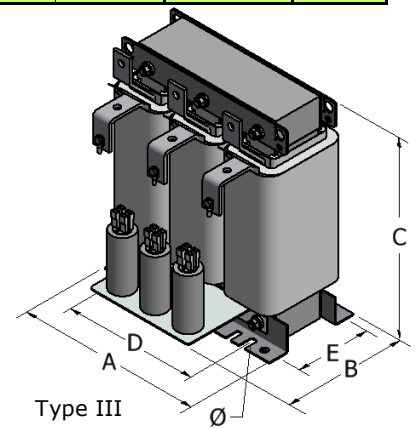

Type III

- * All values show maximum dimensions.
- * Other features, power, voltage, etc., on request.